

User Manual

Item No. 192H

KNIFE & SCISSORS SHARPENER WITH DIAMOND & CERAMIC WHEELS



Spindle Sharpening Wheel Design

- * Minimal amount of metal remove
- * Fast and skill-free use
- * Sharpens in the obliquely vertical direction same as whetstones to keep sharpness longer

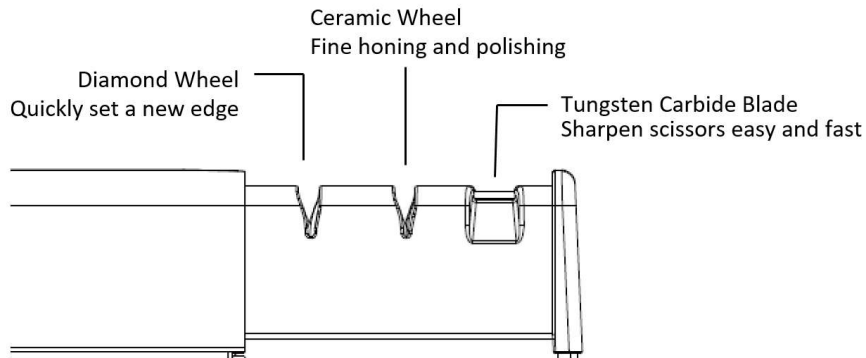

BEFORE SHARPENING:

To prevent the sharpener and table from being cut by knife or scissors, place the sharpener as close as possible to the table edge while sharpening.

Hold the transparent handle and pull the sharpening part out with moderate pressure until it “clicks”. (See Fig. 1) If you don’t hear the click, the sharpener is not fully locked.

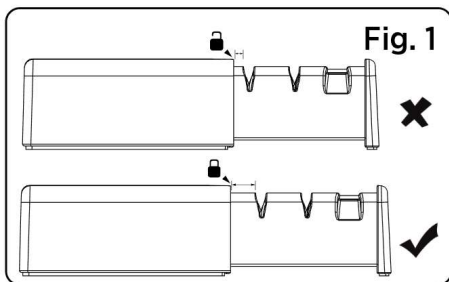

KNIFE SHARPENING INSTRUCTION:

This sharpener is suitable for all knives of double-beveled edge, not suitable for single-beveled edge and serrated edge knives.

1. Insert blade fully and vertically into appropriate sharpening slot at a 90-degree angle to the sharpener. **Gently pull the knife blade with light pressure from heel to tip in direction of indicator arrows.** (See Fig. 2)
No. 1 V-Notch slot (Coarse DIAMOND) - Quickly set a new edge
No. 2 V-Notch slot (Fine CERAMIC) - Hone for a smooth finished edge

Note: Light pressure is sufficient when using the knife sharpener. Heavy pressure might cause to lose control of the knife and could cause possible injury. Carefully and gradually increase pressure until the desired result is achieved.

The No. 2 CERAMIC slot is for fine honing of slightly dull edge. The No. 1 DIAMOND slot is for dull or damaged edge that requires new edge setting. Try to sharpen with No. 2 CERAMIC slot firstly for your valuable knives.

2. Repeat above action until blade is sharp. **Always pull the blade through the sharpening slot from heel to tip, never back and forth.**

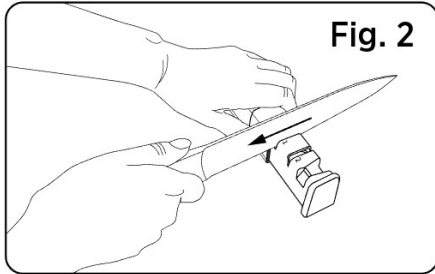

SCISSORS SHARPENING INSTRUCTION:

Note: Scissors blades are single-beveled, only sharpen the side of each blade that has a bevel.

Open your scissors and lay the edge to be sharpened of the beveled side of one blade across the carbide sharpening blade, which is located above the scissors' icon. Place the open hinged scissors blade all the way up to the horizontal carbide sharpening blade, and make sure that the scissors blade is angled to make the bevel side of scissors blade fully lean on the horizontal carbide sharpening blade.

1. **With light pressure pull the blade in the direction of the arrow** with a downward motion all the way through the sharpener following the preset angle on the scissors. (See Fig. 3) Repeat this process several times until you achieve a sharp edge. This may take several passes and you may need to increase your pressure during this process. **Do not push the scissors blade over the sharpening blade.**
2. Repeat the above steps for the second scissors blade.
3. After sharpening the scissors' edge, there are specific rough burrs of metal across the sharpened edges of the blades. Burrs can quickly be removed by setting the scissors back together, and opening and closing them a few times.

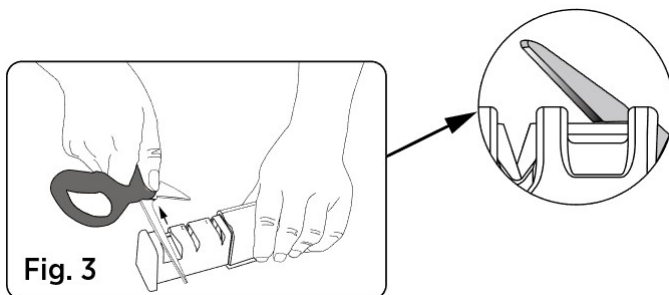

MAINTENANCE:

1. Clean the exterior with a damp soft cloth.
2. Oil or other lubricating liquid is not necessary.

CAUTION: Recommend to wear gloves when sharpening a blade with this product.

WARNINGS: This product is not a toy. Keep out of the reach of children.

***Watch its demo video on YouTube:**

bit.ly/192video

Or scan QR code



***Each SHARPAL product is warranted to be free from defects in material and workmanship for 3 years from the date of purchase under normal wear and tear, except for damage caused by misuse or alteration. THIS WARRANTY APPLIES ONLY TO NON-INDUSTRIAL OR NON-COMMERCIAL USE. If you want to make a warranty claim, please contact us through SHARPAL website or send an email directly to warranty@sharpal.com.**